



SERVICE BULLETIN
#116
WARNING!!!!

THIS SERVICE BULLETIN ADDRESSES SAFETY RELATED INFORMATION. FAILURE TO COMPLY WITH THESE REQUIREMENTS CAN RESULT IN DEATH OR SERIOUS INJURY

DATE: January 17, 2005

TO: Time Export

SUBJECT: Leveling link assembly (16880-1) on VOE-36MHI

THE PROBLEM:

Time Manufacturing has received some reports that a few VOE-36MHI's are failing the periodic dielectric tests. Evidence has shown the failure is caused by moisture accumulating in the fiberglass link insulator, part number 16881-1. This occurrence seems to come about after the unit has been in service for several (5-6) years and the link exposed to excessive amounts of water.

UNITS AFFECTED:

All VOE-36MHI's. Our records indicate all of these aerials were sold to Versalift U K.

SOLUTION:

A tube cover must be welded to the link ends to prevent water from enter the link tubes. In addition, the machined areas of the fiberglass insulator link must be sealed with urethane paint.

WHAT YOU MUST DO:

Locate each aerial and perform the functions as described on the attached “Directions for Service Bulletin 116”. After all instructions have been completed, fill out the “Letter of Compliance” and a “Periodic Dielectric Test” form for each unit. Mail those to:

Time Manufacturing
P.O. Box 20368
Waco, TX 76702-0368
Attn: Customer Service Department

Or you may fax them to 254-399-8463.

WHAT TIME MANUFACTURING WILL DO:

Attached you will find a spreadsheet listing the serial numbers of the units affected by this bulletin. In some instances, the end user has been identified.

Also attached is drawing 32646-1, which details the components of the 16880-1 leveling link assembly. Time will furnish two complete assemblies of the 16880-1, leveling link assembly, to facilitate the execution of this bulletin. In addition, two (2) 32647-1’s, tube covers, are furnished for each aerial.

Upon receipt of the “Letter of Compliance” and a report of the final dielectric results, Time Manufacturing will issue a credit of up to fourteen (14) hours labor at our current warranty rate (\$40.00 USD) for each machine.

Directions for Service Bulletin #116

****NOTE**** Please refer to attached drawing 32646-1

1. Remove the leveling link assembly, A, from the lower boom.
2. Dielectric test the link assembly
 - A. If the assembly passes dielectric
 1. Remove the fiberglass link insulator, B, from A. Please note that one link tube, C, is shorter than the other tube, D.
 2. Clean the machined areas of B to remove dirt, rust, etc.
 3. Seal the machined areas with a high quality urethane paint and set aside to dry
 4. Weld two (2) tube covers, F, one to each end of the link tubes, C & D, as detailed in view A-A. Paint as required.
 5. Reassemble link, insuring D & E are located the same as before disassembly, and install assembly back onto the lower boom.
 6. Dielectric test the complete unit
 - B. If the assembly fails dielectric
 1. Replace the failed link assembly with one supplied by Time Manufacturing or one that was reworked as described below.
 2. Dielectric test the complete unit

Reworking a failed link assembly

1. Remove the fiberglass link insulator, B, from A.
2. Place the insulator in a warm low humidity area for four days. This should dissipate any moisture that might have caused the failure. If an oven is available you can place the link in an oven and heat it to 200 degrees F. **Do not exceed 300 degrees F.**
3. Dielectric test the link again to insure it will pass
4. Clean the machined areas of B to remove dirt, rust, etc.
5. Seal the machined areas with a high quality urethane paint and set aside to dry
6. Weld two 32647-1, tube covers, F, one to each end of the link tubes, C & D, as detailed in view A-A on drawing 32646-1. Paint as required.
7. Reassemble link, insuring D & E are located the same as before disassembly

Serial Numbers for Service Bulletin #116

Serial Number	End User Name
CL9601	
CL9602	
CL9603	
CL9604	
CL9605	
CL9701	
CL9702	
CL9801	NIE
CL9802	
CL9803	
CL9804	
CL9805	
CL9807	
CL9808	
CL9809	
CL9810	
CL9901	
CL9902	NIE
CL9903	NIE
CL010001	NIE
CL010002	Western Power
CL010003	NIE
CL030001	Aquila
CL030002	Aquila
CL030003	Northern Electric
CL030004	Aquila
CL0040001	
CL040002	United Utilities
CL040003	United Utilities
CL040004	
AW9714	ESB
AW9715	Norweb
AW9716	ESB

Letter of Compliance for Service Bulletin #116

This certifies that Service Bulletin #116 has been performed on the following Versalift, Model VOE-36MHI.

Distributor Name_____

Versalift Model Number_____

Versalift Serial Number_____

Date Work Performed_____ Work Performed By_____

Comments_____

Return this form to:

Time Manufacturing
P.O. Box 20368
Waco, TX 76702-0368
Attn: Customer Service Department

Fax-254-399-8463

REV.	ERON NO.	DESCRIPTION	BY	CHKD.	APPR.	DATE
54715	FIRST RELEASE		KCM	.	.	.

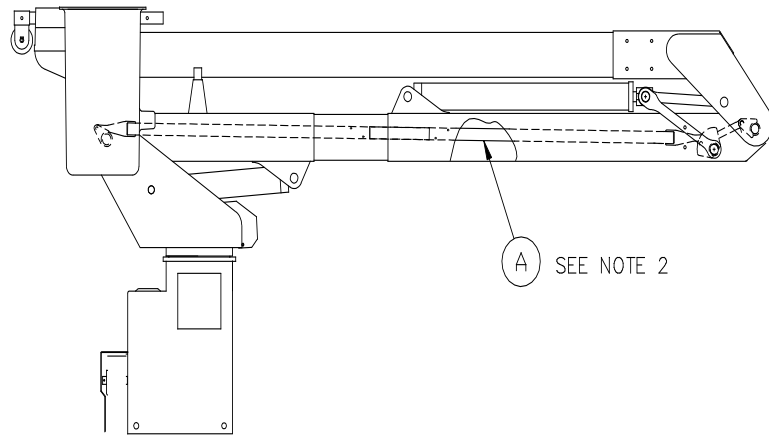

A SEE NOTE 2

SCALE.....N/A

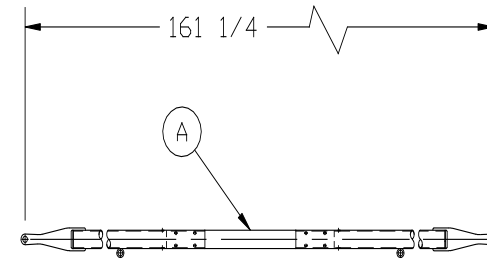

SCALE.....N/A

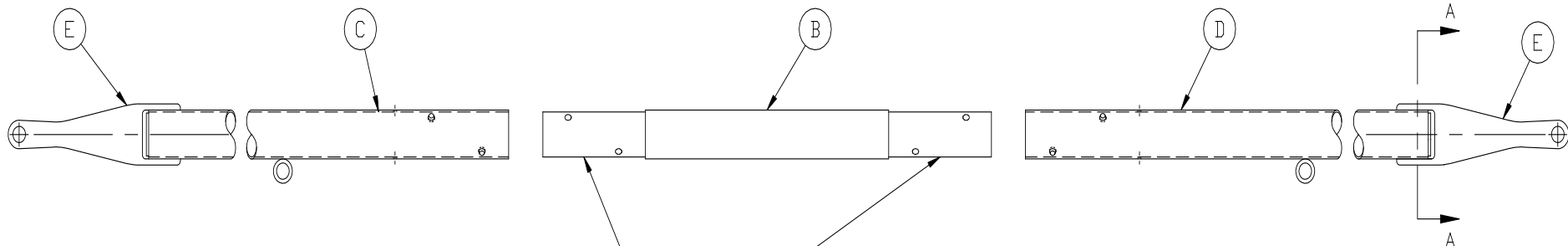

SEAL ALL MACHINED SURFACES WITH POLYURETHANE OR EQUIVLENT.

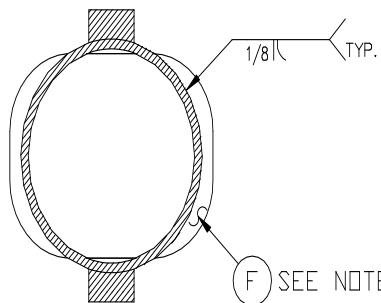

VIEW A-A
SCALE.....1/2

- NOTE:
- 1.) ITEM "F" IS TO BE WELDED ON BOTH ENDS TO SEAL OUT MOISTURE.
 - 2.) ITEM "A" PART NUMBER REFERENCES COMPLETED LEVELING LINK ASSEMBLY.

QTY.	ITEM	PART NO.	DESCRIPTION
2	F	32647-1	TUBE COVER
2	E	16875-1	LINK END
1	D	16901-2	LINK TUBE (68 LG)
1	C	16901-1	LINK TUBE (53 1/4 LG)
1	B	16881-1	LINK INSULATOR
REF	A	16882-1	LEVELING LINK WELD ASSY

LIST OF MATERIAL

<small>UNLESS OTHERWISE NOTED: TOLERANCES: DECIMALS FRACTIONS ± 1/16 .X ± .11 ANGLES ± .XX ± .03 .XXX ± .005 MACHINED SURFACE FINISHES = 125 PROJECTION OF VIEWS ALL DIMENSIONS ARE IN INCHES</small>		MANUFACTURING	DWN. BY	DATE	TITLE
		COMPANY	KCM	01/04/05	SERVICE BULLETIN
<small>THIS PRINT CONTAINS CONFIDENTIAL INFORMATION AND IS SOLE PROPERTY OF THE MANUFACTURING AND IS NOT TO BE DISCLOSED, COPIED, OR REPRODUCED WITHOUT EXPRESSED PERMISSION OF THE MANUFACTURING.</small>	WACO TEXAS	LOCATION	MANUAL		116
		SEE ABOVE	V	-	6
FINISH	---	SHEET	1 OF 1	DWG. NO.	32646-1

